

# Optidrive Applications Support Library

<b>Application Note</b>	<b>AN-ODP-2-045</b>
<b>Title</b>	<b>Using multiple motors in parallel</b>
<b>Related Products</b>	<b>Optidrive P2</b>
<b>Level</b> <b>2</b>	1 – Fundamental - No previous experience necessary 2 – Basic – Some Basic drives knowledge recommended 3 – Advanced – Some Basic drives knowledge required 4 – Expert – Good experience in topic of subject matter recommended

## Overview:

In some applications it is possible to operate multiple motors connected to a single Optidrive P2. This application note described the considerations and guidelines that should be given to such applications in order to select the correct drive and to operate it successfully.

All drives used for multiple motor applications must be configured for open loop V/f speed control only (Parameter P4-01 = 2). All other modes of operation are not permitted. Only standard industrial AC motors should be used for multiple motor applications.

## Wiring Configurations:

The diagrams below shows a common installation setup where a single drive is used to control a larger (>1) number of smaller rated motors.

Configuration 1: Series Connection

**Optional Output Filter**  
(Not required if total motor cable length is less than maximum specified in drive manual)

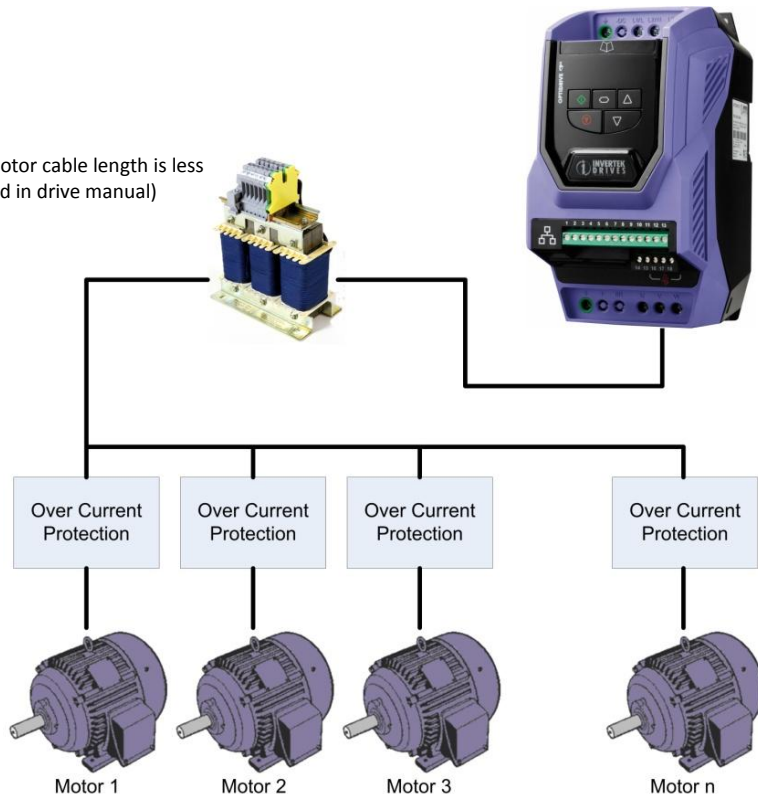

With this connection method a single motor cable is run between the drive and the first motor and connection is then daisy chained from one motor to the next. The cable from the drive to the first motor is therefore typically long and is required to be rated to the combined current [A] ratings of all of the over-current protection devices. This configuration typically results in the Over-current protection being located close to the motor it protects, making the cable run between the over-current protection and the associated motor very short.

The output filter is required only when the accumulative motor cable length is greater than the maximum motor cable length specified for the drive (given in the drive operating manual).

## Configuration 2: Parallel Connection

### Output Filter Normally Required

(Even required when total motor cable length is less than maximum specified in drive manual)

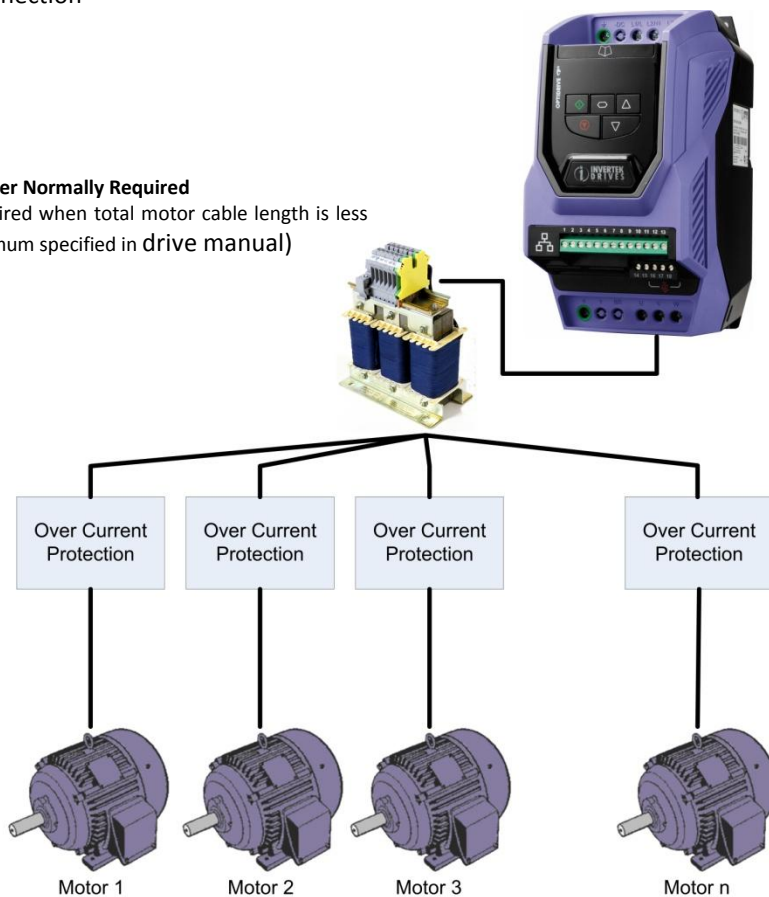

With this connection method individual motor cables are run between the drive and each of the motors with a common connection (star) point located close to the drive. Over-current protection for this configuration is typically located near to the drive so that each motor cable down-stream from the over current protection device is rated only for the motor it protects.

The output filter is normally required for this connection method, even when the accumulative motor cable length is less than the maximum motor cable length specified for the drive (given within the drive operating manual).

## Multiple Motor Applications:

Multiple motor with single drive operation is generally suited to applications where the motors are always required to run at approximately the same speed and where motor loads are not mechanically coupled together.

Drives can be used to run multiple motors in applications where slight motor speed variation (generally only a few percent) does not cause a problem in the overall process being performed (motors speeds are not required to be precisely synchronised). Typical applications might include fans, pumps, or conveyors where accurate speed synchronisation within the application is not a requirement.

Multiple motor with single drive applications require that the drive be in V/f speed control mode (P4-01 = 2). Such applications cannot be run with any other control mode or motor type (refer to drive operating instructions for detail).

## General Rules for Multiple Motor Applications

- Providing that all the motors are permanently connected to the Optidrive P2, the required drive can usually be selected based on the total of the motor current ratings connected.
- The total cable length required should not exceed the maximum allowed for the drive in use – refer to the User Guide for details of the maximum cable length. The allowed total cable length can be increased by 50% if an output filter is used.
- To avoid possible motor damage, each individual motor must be protected by a thermal overload device. The drive over-current protection settings cannot be used to protect multiple motors.
- The drive should be operated in V/F Mode only. Other control modes cannot be used in this type of application.
- Only standard AC industrial three phase motors should be used. Other motor technologies are not suitable for multiple motor operation.
- The Effective Switching Frequency Parameter (P2-24) should be set to the minimum value (normally 4kHz).
- The Spin Start function (P2-26) cannot be used

**Providing the above design rules are met and the motors are permanently connected to the drive, the drive should be sized based on the total nameplate *current* (not kW or HP) of the connected motors.**

## Example of Drive Sizing with permanently connected motors

An Optidrive P2 is required to control six fan motors as follows:

2 x 0.75kW, 1.9 Amps FLC

2 x 2.2kW, 5.2 Amps FLC

2 x 5.5kW, 10 Amps FLC

The Supply Voltage is 3 Phase 400 Volts. The cable length required is 10metres per fan, wired in series (configuration 1 - above).

Total Amps Required = 1.9 + 1.9 + 5.2 + 5.2 + 10 + 10 = 34.2 Amps. Referring to the Optidrive P2 User Guide, an 18.5kW 400V drive will provide 39Amps output current and would be suitable. The 'Motor Rated Current' parameter (P1-08) should be set to 34.2 Amps. Each motor requires an individual overload device to protect it, and an output filter is not generally required as the motors are series connected and motor cable length is less than the maximum allowed for this drive model.

## Applications where Individual Motors are Not Permanently connected to the Drive

In some applications it might be desirable to use a single drive to operate multiple motors where all of the motors are not operating at the same time (are not always permanently connected to the drive output). Motors might be selected or deselected by means of contactors or switches located between the individual motors and the drive output.

In such cases the best solution is to design the control system in such a way that motors cannot be connected or disconnected whilst the drive is enabled and running. Attempting to start a motor by closing a contactor or switch on the output side of the drive whilst the drive is enabled is likely to cause over current trips on the drive and prohibit operation.

If an application requires that different motors are run at different times (for example; in a bank of 6 fans, any number or configuration of fans might be selected to run at any particular time) then the sequence for changing the motor fan bank configuration would be as follows:

- Disable the drive via the run / Enable signal, and allow the drive to ramp the motors down to standstill
- Operate the Contactors to connect / disconnect the required motors to / from the drive
- Re-Enable the drive run signal to restart the system

Whilst this means that all motors must stop before the motor configuration can be changed, it ensures that nuisance over-current trips are not encountered.

## Example Interlock Circuit to prevent motor switching whilst drive enabled

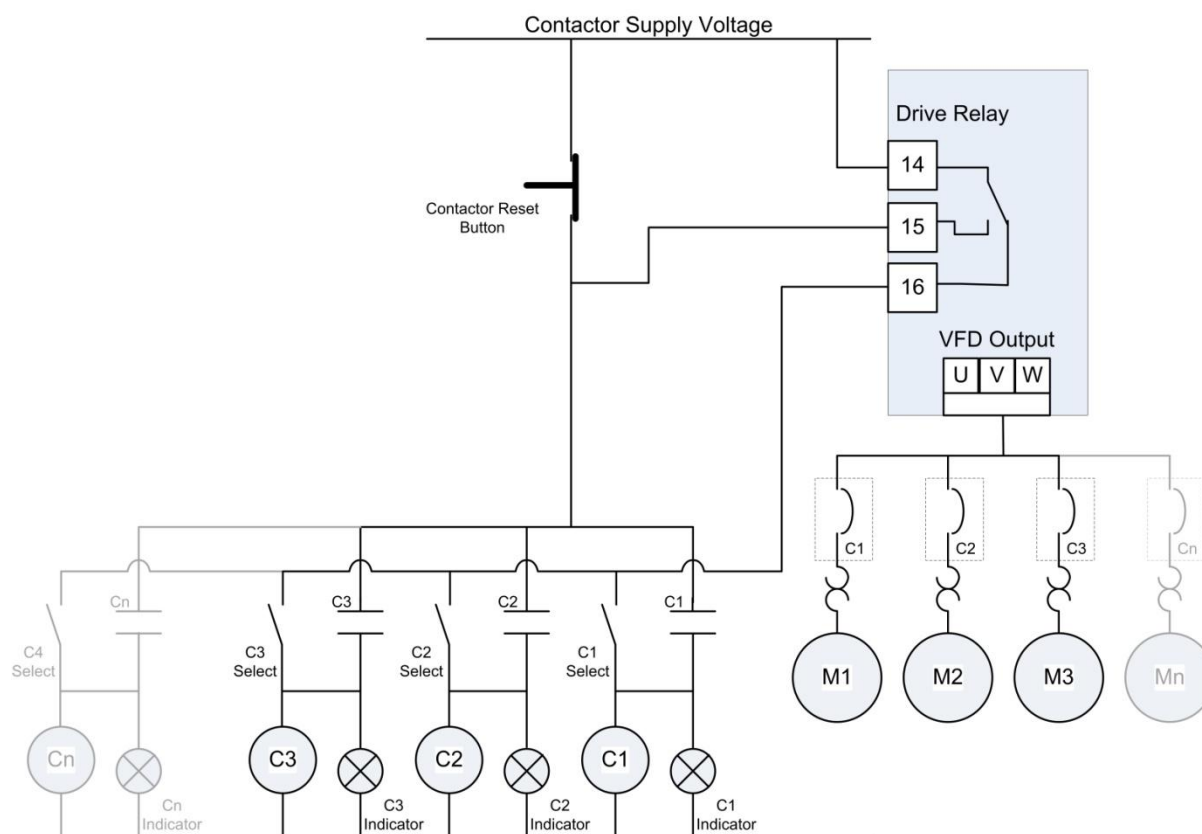

To select a motor the appropriate contactor select switch is closed (C# Select) whilst the drive is disabled. To deselect a motor the appropriate contactor select switch is opened and the contactor reset button pressed whilst the drive is disabled. Selected motors are shown by the corresponding indicators (C# Indicator).

The drive relay will need to be set to switch on a drive enabled condition. This is done by setting P2-15 to '0'. Selecting or deselecting of motors is not possible once the drive is enabled / running and the drive relay closes.

The supply requirements to operate the contactors must not exceed the contact rating of the drive relay. The Drive relay maximum rating is 250Vac @ 6A / 30Vdc @ 5A.

## Applications where Motors are Connected Whilst the Drive is Running

It is possible to connect and disconnect motors whilst the drive output is operating. However in such applications there is a need to oversize the drive, and as such it is often cheaper to purchase individual drives for each motor.

Where individual motors need to be started or stopped without decelerating the drive to standstill (through switches or contactors on the output) the drive has to be oversized to allow for the maximum possible motor starting current. When motors are started in this way (referred to us Direct On Line starting) the inrush current can be up to seven times the full load current of the motor, and so the drive must be capable of delivering this current without tripping.

## Example of Drive Sizing when Motors are Connected Whilst the Drive is Running

An Optidrive P2 is required to control six fan motors as follows:

2 x 0.75kW, 1.9 Amps FLC

2 x 2.2kW, 5.2 Amps FLC

2 x 5.5kW, 10 Amps FLC

The Supply Voltage is 3 Phase-400 Volts. The cable length required is 10metres per fan, wired in parallel (configuration 2 - above).

Worst case for the application is where the drive is already running without motors connected and all 6 motors are connected simultaneously. In this application the output current required would be

$$\text{Total Current} = 7 \times (1.9 + 1.9 + 5.2 + 5.2 + 10 + 10) = 239.4\text{Amps}$$

Since this is an overload current, the overload rating of the drive could be used.

If the drive overload rating is 150% of the continuous rating of the drive then the continuous drive rating for this application would need to be  $239.4 / 1.5 = 159.6$  Amps, therefore a 90kW 400V drive would be required. In this case, it may be more cost effective to use 6 smaller drives rather than 1 large drive.

In the case of this application the motor wiring configuration is parallel; hence an output line reactor is required.

Revision History			
Version	Comments	Author	Date
1.00	Application Note Created	JP	03/03/12